

IDEAL Waste Management

Dairy industries and Agri-Food Industries

(AFI)

IDEAL
Technologies

IDEAL Offer

- **Optimized logistics** : Reduced storage space and waste streams control on site
- **Treatment**: Emptying packaging on site and separation of containers/contents (liquids)
- **Recycling**: Effluents and PP yoghurt containers recovery
- **Hygiene and safety**: Automated process and deodorant/ionization option
- **Anticipation of new environmental standards**

Figures

- **Types of waste**: Full yoghurt and milk bottles
- **Materials** : PP-PS Alu, plastic packaging, filled cardboard, metal cans, bricks , HDPE, PET
- **Emptying** > 90% - repackaged milk
- **Compaction ratio** : Approx. 15 :1
- **Noise level** : approx. 55 db
- **Machine size** : 3 m3 - **Weight** 1100 kg
- **Limited maintenance** (no hydraulics)
- **Peripherals** : sorting table / upstream feeder / downstream collector

Location

300 machines implanted

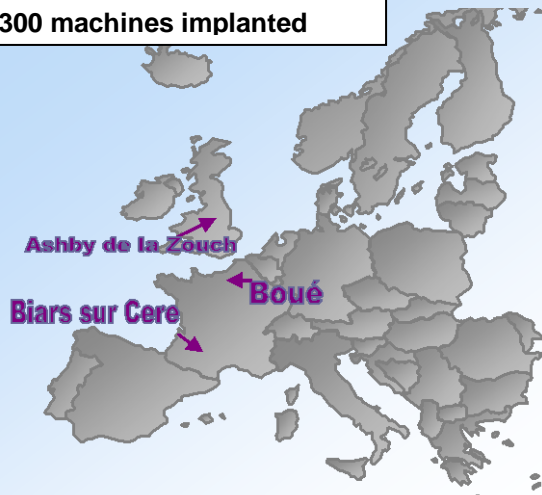

revolution™ 1 to 4 M3/H

revolution™ 500 > 4 M3/H
revolution™ 200 > 1 M3/H



Onsite waste depackaging for materials recovery

1 – Manual or automatic supply: brick, HDPE

2- Spining Draining



Recovery of liquids and solids through the programmable screw

Collecting

3-Recycling Recovery

IDEAL Dairy Industry

IDEAL Waste Management

Dairy industries and Agri-Food Industries

IDEAL
Technologies

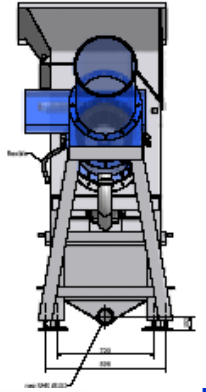
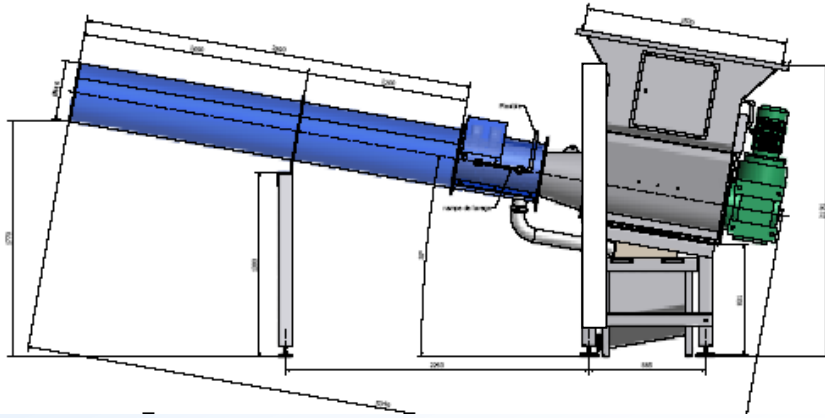
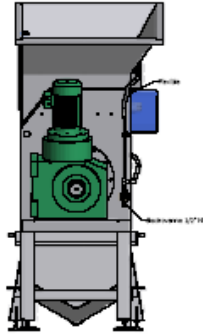

Integrated unit : unloading – packaging emptying – recycling/recovery



Eric DURIVALT

e-mail : contact@idealtechnologies.fr
Website : www.idealtechnologies.fr

3 70

IDEAL Dairy Industry